

ASV Valves

*Electric valve with Atmospheric Backflow
Prevention For Residential Systems*



TABLE OF CONTENTS

Product Overview	3
Features and Benefits	4
Product Comparisons	9
Technical Information	10
Product Explanation.....	10
Product Performance.....	10
Installation and Operating Instructions.....	11
Installation Detail.....	12
Principles of Operation for All Hunter Valves	13
ASV Replacement Parts.....	14

PRODUCT OVERVIEW

The same Hunter quality found in all of our remote control valves is also found in the ASV family. Offering the perfect combination of versatility and economy, these electric valves with atmospheric vacuum breakers included in one unit make back-flow prevention effortless in above ground installations. Highly popular in some areas, these valves offer the most in performance and reliability for a large variety of residential applications. In irrigation systems requiring retrofit to an existing system, the ASV is an obvious choice because of its compatibility with systems using other brands. While designing the ASV, Hunter was aware of four main stipulations required by contractors who use anti-siphon valves:

- availability in threaded or slip versions
- captive parts for easy servicing
- ability to withstand harsh environmental conditions
- minimal pressure loss across the valve

For proven reliability that meets all the listing requirements of the regulatory agencies that set the standards for anti-siphon valves, you can depend on the Hunter ASV.



FEATURES AND BENEFITS

3/4" and 1" Body Options...

Handles flow requirements for virtually any residential system



3/4" Inlet/Outlet

1" Inlet/Outlet

The ASV features the two most popular sizes on the market, the 3/4" (20mm) and 1" (25mm) female inlet/outlet. With these two sizes the valve will handle flows from 1 GPM to 30 GPM (0.23 to 6.8 m³/hr; 3.8 to 114 l/min) without any adverse effects.

Backflow Protection meets Regulating Agencies' Standards...

City Code requirements are addressed. The Hunter ASV anti-siphon valve is fully compliant with all backflow regulating agencies. The ASV meets I.A.P.M.O. and A.S.S.E. 1001 listing specifications as well as the approval of the City of Los Angeles, California.

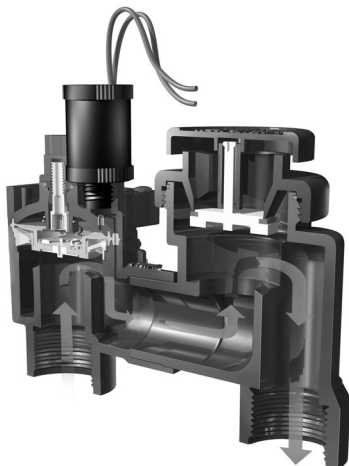

Slip Version...

Providing ways to reduce installation time and callbacks



Hunter is very aware of the importance of saving time on any job site. With the ASV available as a slip version, new installs as well as retrofits are very quick. The slip configuration permits a solvent-weld connection directly to PVC pipe, which makes it a very adaptable valve for the residential market. This solvent-weld slip joint eliminates the chance for threaded fitting leaks. And, with a slip version valve, saving money on male adapters or other fittings is a given. Great benefits to consider when installing anti-siphon valves.

Captive Bonnet Screws, Diaphragm and Solenoid Plunger...

No lost parts during servicing

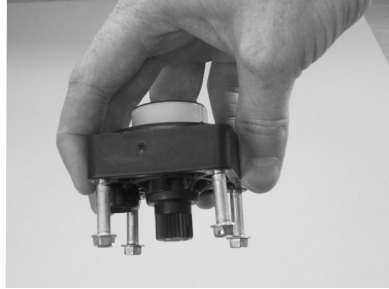

When servicing is required, the ASV is the valve that makes it easy. All parts are captive within the valve, including the screws, diaphragm and solenoid plunger. Captive parts have always been a requested feature by our customers, assuring nothing will be lost in the mud. The ASV also features screw through-holes in the valve body for trouble-free screw placement. If dirt gets into these holes it's not a problem because as the screw is turned into the body, the dirt comes out the bottom. (It sounds simple, but other brands actually require removal of the valve to clean out the debris.)

Captive Anti-Siphon Poppet...

Anti-Siphon cap replacement is no longer a frustrating experience

A simple, yet important feature of the Hunter ASV valve is its captive anti-siphon poppet or "float". Many other brands of anti-siphon valves require the manipulation of the poppet with fingers while trying to replace it. Before the cap can start on the body threads, the poppet must be held secure



with fingers. Otherwise, the poppet will drop into the body at an awkward angle while screwing the cap onto the valve body. To a contractor in a hurry, this can be a frustrating, if not time consuming, experience.

Triple-Tool Bonnet Fasteners...

Tool choices for bonnet removal

Many customers find their toolboxes always seem to be lacking the exact tool needed to remove a valve bonnet.

With the Hunter ASV's

triple-tool fasteners

that frustration

is a situation

of the past.

The fasteners, (screws) captive within the bonnet,

are designed to be

removed by any one of three tools:

a 5/16" nut driver, Phillips, or slotted

screwdriver. In addition to captive

convenience, another innovative

characteristic of the ASV fastener is that it

is specifically designed for use in plastic

with its large gain threads. This large

gain allows it to thread true and very

quickly into the valve body, which means

no chance of thread stripping and solid

sealing between the bonnet and body.



FEATURES AND BENEFITS (CONTINUED)

150 PSI Rating...

*Made of durable materials
to conquer the outdoors*

If you are in the market for a plastic anti-siphon valve that will withstand constant environmental abuse and take the pressure, the ASV is your choice. The plastics used in the ASV valve are UV sunlight resistant approved for above ground use. Featuring also heavy-duty construction built with an ABS bonnet, this valve takes up to a constant 150 PSI (10.3 bars; 1034 kPa) much more consistently during those hot summer temperatures. The superior design of the ASV helps eliminate the reduction in pressure ratings when temperatures go up; a common occurrence with 100% PVC constructed valves.

Heavy-duty Solenoid...

Provides dependable operation and long life

The entire line of Hunter valves has something in common: the same heavy-duty five-year warranty solenoid. The solenoid is fully encapsulated in a heavy-duty glass-filled nylon casing which is the only assured way the solenoid will work consistently in stressful environments. Other types of solenoid construction, such as the potted type, may over time fail due to the potting separating from the walls of the solenoid casing.

Installers will find that not having to stock two or three different solenoids for valves of the same manufacturer are a real plus. Another plus is the solenoid's captive plunger, which enables easy



servicing of the solenoid but eliminates the chance for any lost internal parts. It only takes 1 1/2 turns to remove or replace the solenoid which makes twisted solenoid wires a non-issue (a tremendous benefit to installers or maintenance people who work with valves).

The ASV solenoid is unique because it operates on a reverse flow principle. The center hole in the solenoid bowl is an inlet port, instead of an exhaust port as found in other manufacturers valves. This solenoid is especially efficient when installed on long wire runs (voltage drop issues), and under high system pressures because water pressure actually helps open the solenoid, not impede it.

A big advantage to this reverse flow action is that it reduces potential large pressure spikes against the valve. Such spikes could cause damage not only to the valve, but to other components of the irrigation system as well. With the ASV, when a surge pressure spike hits the closed valve, the solenoid plunger will open slightly to allow the spike to travel downstream and dissipate through the zone piping, minimizing any damage that could occur. The solenoid plunger then closes immediately, preventing unscheduled system operation.

Debris Tolerant...

Designed to eliminate failure caused by debris

With the ASV valve installed in the irrigation system, callbacks for weeping valves are a thing of the past. The ASV is debris tolerant because of its “knife-edge” body seat and large filter built into the diaphragm. Because of its knife-edge, the body seat is resistant to debris catching under the diaphragm during valve closing, making it very difficult for debris to become trapped by the diaphragm. The ASV filter is designed to keep contaminants out of the upper bonnet chamber keeping the inlet/exhaust ports clean and free from clogging.

Internal Manual Bleed...

Completely dry manual operation

For fast manual operation, a quick turn of the solenoid allows water to bleed off of the top of the diaphragm through the downstream piping and, as a result, opens the valve. All the water goes through the valve, which means no more water continuously leaking all over the user and the ground.

Incredible Low Pressure

Loss Characteristics...

System performance is not affected in low pressure situations

Hunter’s ASV has become an industry leader when it comes to low-pressure losses through an anti-siphon valve. As a rule, anti-siphon valves experience high-pressure losses because of the backflow device attached to the valve. The Hunter ASV design incorporates loss ratings of 30 to 50% less than other industry anti-siphon valves. At 10 GPM, both the 3/4" and the 1" valves only have a 2 PSI loss (.14 bars; 13.79 kPa) and at 25 GPM, the 1" valve only has a 6 PSI loss (.41 bars; 41.37 kPa).

Adjustable Flow Control...

Flow adjustment and servicing made easy

Flow management is a simple process when using the Hunter ASV with its standard flow control handle. When fine tuning the system, adjust to the desired zone flow either by hand (using the removal twist handle) or with a flat bladed screwdriver. If necessary, the easy-to-turn flow control handle completely shuts the valve off without the possibility of damage to the diaphragm, even under maximum pressure and flow conditions.

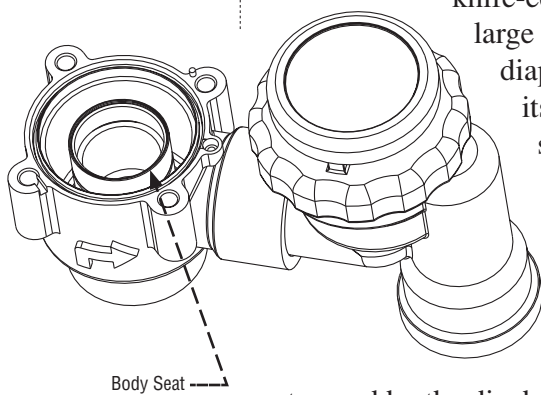

FEATURES AND BENEFITS (CONTINUED)

Rigid Diaphragm Support...

Prevent stress failure in tough conditions

On every valve in the industry, the only moving component in the valve itself is the diaphragm. With that being the case, it is very important to keep any extra stresses on the diaphragm to a minimum. The ASV diaphragm is fully supported by an ingenious diaphragm support ring designed to prevent premature stress failure. The ring is molded with radiuses and contours to specifically enhance the diaphragm life. The support is also designed with small holes in it. These holes allow water to enter under the diaphragm to keep the diaphragm from sticking to the support ring after periods of non-use.

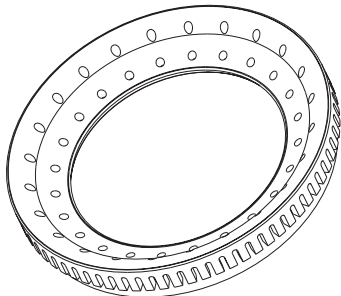

*Diaphragm Support Ring
prevents stress failures*

12 VDC Heavy-duty Latching Solenoid...

When AC power is not available

The standard for battery power in the irrigation industry has become 12 VDC. Hunter has developed a 12 VDC latching solenoid to meet this demand for those valve applications requiring battery power. The new latching solenoid has the same characteristics as Hunter's 24 VAC solenoid, which makes it interchangeable within the entire Hunter Industries valve line. This 12 VDC solenoid is available as a separate part

number (P/N 458200) to add to any Hunter valve, including the ASV.

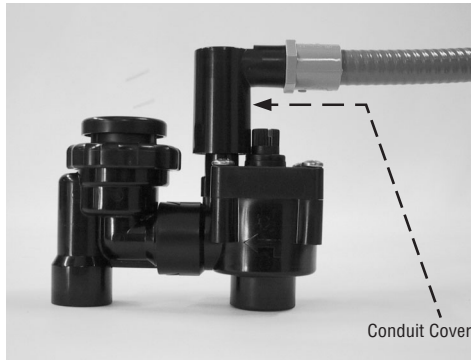

Solenoid Conduit Cover Available...

Meet electrical codes when needed

When the ASV valve is to be used in a city that requires above ground wiring to be enclosed in conduit, Hunter's solenoid conduit cover is the answer. The cover fits over the top of the solenoid and allows the attachment of a threaded fitting or pipe to the solenoid. This requirement is very regional so it is recommended to contact local building departments to determine if the cover and wire conduit are needed.

PRODUCT COMPARISONS

FEATURES	Hunter® ASV	Rain Bird® ASVF	Irritrol® 2700APR	Toro® Flow-Pro
Internal Manual Bleed	✓	✓	✓	✓
ABS Bonnet for Increased Heat Tolerance	✓			
Buttress Threads on Antii-Siphon Cap for Increased Strength	✓	✓		
Captive Diaphragm	✓			
Captive Bonnet Screws	✓		✓	
Captive Antii-Siphon Poppet	✓	✓	✓	
Three-way Stainless Steel Bonnet Screws	✓			
Easy Bonnet Removal (only 4 Screws)	✓			
1½ Turns or Less to Remove Solenoid	✓			
150 PSI Rated Operating Pressure	✓	✓	✓	✓
Less Than 2.5 PSI Loss at 10 GPM in 3/4" Valve	✓			
Less Than 6.5 PSI Loss at 25 GPM in 1" Valve	✓			
Reverse-Flow Solenoid for Reduced Line Surges	✓			
Encapsulated Solenoid Plunger	✓	✓	✓	✓
Interchangeable Solenoid with All Valves in Catalog	✓			✓
Inlet/Outlet Solvent-Weld Slip Option	✓			
Vent Holes in Diaphragm Support	✓			
Optional Conduit Cover	✓	✓		
Optional DC Latching Solenoid	✓	✓	✓	

Rain Bird® is a registered trademark of Rain Bird Sprinkler Manufacturing Corp.
 Irritrol® is a registered trademark of Irritrol Systems
 Toro® is a registered trademark of the Toro Company

TECHNICAL INFORMATION

MODELS

- ASV-075 – 3/4" anti-siphon electric valve with flow control, NPT inlet/outlet
- ASV-101 – 1" anti-siphon electric valve with flow control, NPT inlet/outlet
- ASV-075-S – 3/4" anti-siphon electric valve with flow control, Slip inlet/outlet
- ASV-101-S – 1" anti-siphon electric valve with flow control, Slip inlet/outlet

DIMENSIONS

- ASV-075
 - Height: 5 1/2" (14 cm)
 - Length: 5 3/4" (11 cm)
 - Width: 2 1/2" (6 cm)
 - Female inlet/outlet: 3/4" NPT or Slip
- ASV-101
 - Height: 5 1/2" (14 cm)
 - Length: 6 1/4" (15.9 cm)
 - Width: 2 1/2" (6 cm)
 - Female inlet/outlet: 1" NPT or Slip

OPERATING SPECIFICATIONS

- Flow: 1 to 30 gpm (0.23 to 6.8 m³/hr; 3.8 to 114 l/min)
- Pressure: 20 to 150 psi (1.4 to 10.3 bars; 138 to 1034 kPa)
- Heavy-duty standard solenoid: 24VAC
 - At 60 cycles, 363mA (8.7 VA) inrush current
170mA (4.1 VA) holding current
 - At 50 cycles, 448mA (10.8 VA) inrush current
200mA (4.8 VA) holding current
- Solenoid coil resistance: 24.5 Ohms
- Anti-siphon must be installed a Minimum of 6" (15.2 cm) above the highest point of water in the system and sprinklers it serves.
- No automatic irrigation valve can be located down-stream of the anti-siphon valve.
- Anti-siphon valves must not be operated continuously for more than twelve (12) hours.
- Consult local codes.
- IAPMO, ASSE 1001 and City of Los Angeles approved

PRODUCT EXPLANATION

EXAMPLE: **ASV - 101 - S**

MODELS

ASV-075 = 3/4" Anti-siphon Electric Valve with Flow Control
ASV-101 = 1" Anti-siphon Electric Valve with Flow Control

OPTIONS

S = Slip x Slip

PRODUCT PERFORMANCE

Pressure Loss in PSI

GPM	3/4"	1"
1	1	1
5	2	2
10	2	2
15	3	3
20	6	6
25	10	6
30	15	9

Pressure Loss in Bars

m ³ /hr.	3/4"	1"
0.23	0.07	0.07
1.14	0.14	0.14
2.27	0.14	0.14
3.41	0.21	0.21
4.54	0.41	0.41
5.68	0.69	0.41
6.81	1.03	0.62

Pressure Loss in kPa

l/min	3/4"	1"
4	6.89	6.89
19	13.79	13.79
38	13.79	13.79
52	20.68	20.68
76	41.37	41.37
95	68.95	41.37
114	103.42	62.05

Charts based on full-open flow control position

AUTOMATIC ANTI-SIPHON VALVE INSTALLATION AND OPERATING INSTRUCTIONS

Installation

All Hunter Industries Anti-Siphon Valves should be installed above ground and at least 6 to 12 inches above the highest sprinkler to prevent back pressure or drainage. Installations at any height lower than this may result in unsafe backflow condition. Consult your local codes to verify this height for your specific area. Do not install other shut-off valves between the anti-siphon valve and the sprinkler heads. Do not bury this product.

In areas where freezing conditions occur, make provisions for draining the system by using both a drain valve and a stop-and-waste shut-off valve installed on the main line feeding the sprinkler system. To assure complete drainage of the valve after the water supply is shut-off, electrically energize each valve for at least 2-3 minutes. This will vent the upper cavity of the valve allowing maximum drainage.

The ASV-075 and ASV-101 Anti-Siphon valves are rated for use up to 150 PSI at 110° F. The flow control can be used to reduce the downstream pressure on high-pressure installations. Devices shall not be subjected to continuous pressure for more than twelve (12) hours.

To install the valve:

1. Flush the line thoroughly before installation to clean out any debris.
2. Use only Teflon paste or tape on all threaded valves to pipe connections.
Note: Do not use Pipe Dope or solvent cement on threaded connections. After applying the paste or tape around the male adapter or nipple threads, insert the male adapter or nipple into the valve. Tighten by hand, then using a wrench, turn the male adapter or nipple 1/2 turn to ensure a good seal.

Over tightening of fittings may break the valve.

3. If using male adapters or a slip version of the ASV, glue the male adapters or valve to the pipe (consult your local codes for type of glue to be used). If using a threaded nipple, use the same procedure as above the threaded connections on the mainline and downstream piping.
4. To test the connections for water leaks, turn on the main water supply. The valves may open when first pressurized and will close within 1 minute.

Electrical Connection

All Hunter Industries Automatic Anti-Siphon Valves are supplied with a 24 volt solenoid. Connect the solenoid only to a controller that uses an approved class 2, 24 VAC transformer a power source via approved direct burial type wire. Valve wires can be buried. All wire splices should be joined using waterproof connectors. Run one common wire to each location to serve all the valves at that location. Note: Allow enough slack in the solenoid wires to enable removal of the solenoid if future maintenance should be required.

Warning: Do not connect the solenoid leads to 110 VAC house current, serious injury or electrocution could result.

OPERATING INSTRUCTIONS (CONTINUED)

Manual Operation

The ASV-075 and ASV-101 utilize an internal manual bleed. To operate the valve manually, turn the solenoid 1/4 turn counterclockwise. Turn the solenoid 1/4 turn clockwise to stop the manual operation. The valve may remain open for up to one minute after the manual bleed is closed.

Adjustment of Flow Control

Turn the flow control handle counterclockwise until it stops. Open the valve electrically or manually. With the valve open and the system operating at design pressure, turn the flow control handle clockwise until sprinkler performance is diminished slightly (this reduction can be observed by a decline of sprinkler radius). Then, turn the flow control handle counterclockwise again, just slightly, to return to the correct radius. The appropriate valve flow is now set for that sprinkler zone.

INSTALLATION DETAIL

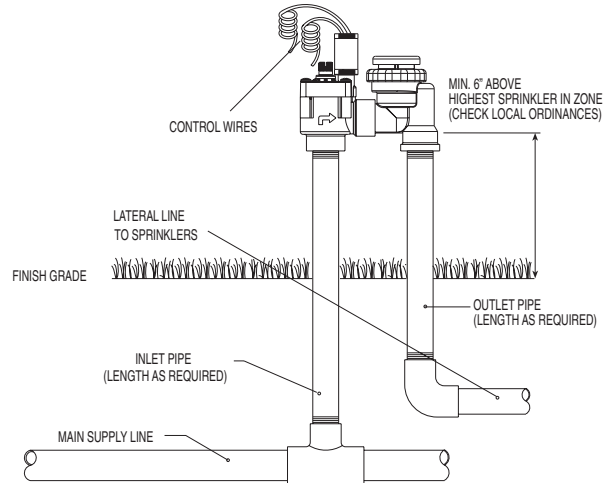

Hunter® ASV-NPT

PRINCIPLES OF OPERATION FOR ALL HUNTER VALVES

Pressurized water enters the valve from the system mainline. A small filtered orifice in the diaphragm allows this water to flow into the bonnet chamber or topside of the diaphragm, filling it completely when the valve is closed. The valve stays closed as long as the solenoid piston or plunger is not lifted off of the solenoid bowl “inlet” port, which is in the center of the solenoid bowl.

The mechanics behind the valve staying closed has to do with the formula: $P \times A = F$ (where P is water pressure, A is the diaphragm surface area and F is an amount of force exerted on the diaphragm). All irrigation valves are designed so that their diaphragms have approximately twice the area exposed to pressurized water on the top of the diaphragm than on the bottom. When water pressure (main line) is exerting itself on the top and bottom of the diaphragm equally there will be approximately twice the force exerted downward than upward. This difference of force keeps the valve in the closed position.

Opening a Valve Electrically

When a valve is operated electrically via a controller, 24 VAC is allowed to flow through the valve solenoid energizing it and allowing it to “suck up” the plunger (lifting it off of the inlet port). With the plunger in an elevated position, the pressurized water in the bonnet chamber is allowed to vacate through a second “exhaust” port, discharging downstream through the lateral piping. With this pressure relieved from the top of the diaphragm, the pressure is now greater on the bottom than the top of the diaphragm. A greater force contributed by the pressure

on the bottom of the diaphragm pushes up on the diaphragm causing the valve to open.

Opening a Valve Manually

The same principle is at work when a valve is manually opened using the manual bleed. The pressure on top of the diaphragm is released when the manual bleed is opened. The manual bleed in a Hunter valve is done “internally” through the exhaust port in the solenoid bowl. When the solenoid is turned a $\frac{1}{2}$ turn, the plunger is lifted off of the inlet ports allowing pressurized water to be released downstream through the lateral piping. With an internal bleed system, the area surrounding the valves is kept dry because no water is bled into the atmosphere.

Closing a Valve

When the controller stops the flow of 24 VAC through the solenoid, the solenoid plunger is released and forced downward by a plunger spring and covers the inlet port. This covering stops the discharge of water through the exhaust port and allows the bonnet chamber to pressurize up to mainline pressure. As the pressure increases, the diaphragm begins to close as a result of an increasing force exerted on it. Remember, as pressure increases, the force increases because the area exposed to water pressure is greater on top of the diaphragm than on the bottom of the diaphragm. The valve will be completely closed when the diaphragm seat meets the body seat.

ASV REPLACEMENT PARTS

Item	Description	Part No.	
①	Solenoid Assembly (Includes Parts 2 & 3)	434100	
	12VDC Latching Solenoid Assembly	458200	
②	O-Ring	262600	
③	Solenoid Seal	364400	
④	Bonnet Screw	424200	
⑤	Bonnet with Flow Control	379405	
⑥	Spring	266000	
⑦	Diaphragm Assembly	332100	
⑧	Diaphragm Support	331300	
⑨	Threaded Cap	3/4"	407600
		1"	409700
⑩	O-Ring	3/4"	407500
		1"	411300
⑪	Piston Assembly and Seal	3/4"	407700
		1"	409800
⑫	Body	3/4" NPT	437715
		3/4" Slip	437720
		1" NPT	437705
		1" Slip	437710
⑬	Flow Control Handle	269200	

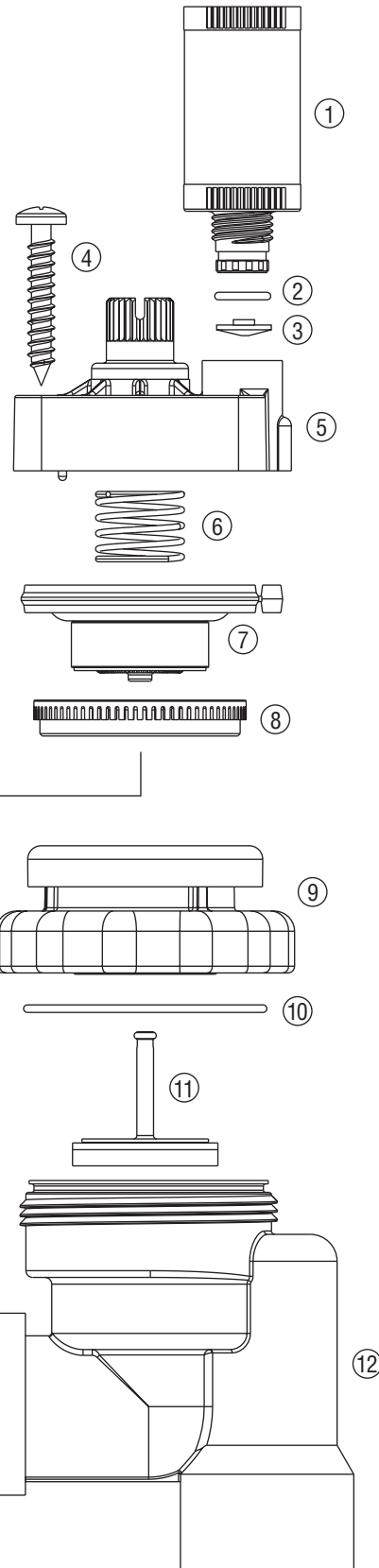

Hunter®

Hunter Industries Incorporated • The Irrigation Innovators
1940 Diamond Street • San Marcos, California 92069 • TEL: (1) 760-744-5240 • FAX: (1) 760-744-7461
www.HunterIndustries.com

© 2001 Hunter Industries Incorporated
P/N 700734 LIT-321 12/00