

RSD Series Rain Sensor “Dial into the Convenience and Value”

The Rain Bird RSD Series Rain Sensor is an easy to install, durable and visually pleasing rain sensor device suitable for 24 VAC residential and commercial applications. This high-quality product saves water and extends irrigation system life by automatically measuring precipitation and keeping irrigation systems from watering in rainy conditions.

The RSD Series Rain Sensor offers the flexibility of multiple rainfall settings with just the twist of a dial, an adjustable vent ring to control drying time and a 25' length (7,6 m) of UV resistant extension wire for installation convenience.

All this, a 5-year “No Hassle” warranty and a great price add up to the matchless convenience and unsurpassed value you expect from Rain Bird, the industry choice in irrigation controller products.

Features

- Multiple Rainfall Settings from 1/8" – 3/4" (5 - 20 mm) are quick and easy with just the twist of a dial
- Adjustable vent ring helps control drying time
- High - grade, UV resistant polymer body resists the elements
- Available in rugged bracket version (RSD-BEx model comes with 5" aluminum bracket) or conduit version (RSD-CEx) for a clean and professional look.
- 25' (7,6 m) of UV resistant extension wire offers an easy connection to irrigation controllers
- Works with all popular 24 VAC controllers
- UL, cUL listed; CE, C-Tick approved
- 5 - year “No Hassle” warranty
- Toll - free Technical Service (800) 247-3782 (U.S. and Canada only)

Electrical Specifications

- Application: Suitable for low voltage 24 VAC control circuits and 24 VAC pump start relay circuits*
- Switch electrical rating: 3A @ 125/250 VAC



- Capacity: Electrical rating suitable for use with up to ten 24 VAC, 7 VA solenoid valves per station, plus one master valve
- Wire: 25' (7,6 m) length of #20, 2 conductor extension wire. Short lead for normally open (N.O.) installations
- * Not recommended for use with high voltage pump start, pump start relay circuits or devices.

Dimensions

RSD-BEx

- Overall Length: 6.5" (16.5 cm)
- Overall Height: 5.4" (13.7 cm)
- Bracket Hole Pattern: 1.25" (3.2 cm)

RSD-CEx

- Overall Length: 3" (7.6 cm)
- Overall Height: 2.75" (7 cm)

Models

- RSD-BEx (rain sensor w/ bracket, extension wire)
- RSD-CEx (rain sensor w/ threaded adapter, extension wire)

How to Specify/Order:

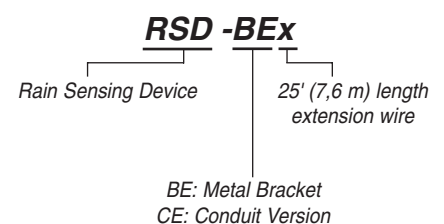



Specifications

The rain sensor shall employ an electro-mechanical actuating device designed to cause a circuit interrupt that temporarily disables the irrigation controller during periods of significant rainfall. The device shall automatically restore the controller to a normal operating condition after a period of time subsequent to the rainfall. The device shall be suitable to be wired – normally closed (N.C.) – in series with the valve common; and, shall include a short-lead to allow wiring Normally open (N.O.) when necessary.

The device shall be of rugged construction to withstand the elements, including exposure to sunlight (U.V.)

The device shall include a U.L. listed, 3A @ 125/250 VAC rated electrical switch. The device shall be of sufficient capacity to be used with a maximum of three 24 VAC, 7 VA solenoid valves per station, plus one master valve.

The rain sensor shall incorporate a provision that allows the installer to select from several rainfall settings. The setting increments shall be displayed in both English and metric units. The device shall include a vent ring to help control drying time of the mechanical components.

The Rain Bird RSD Series Rain Sensor shall be manufactured by Rain Bird Sprinkler Mfg. Corp., Glendora, California .

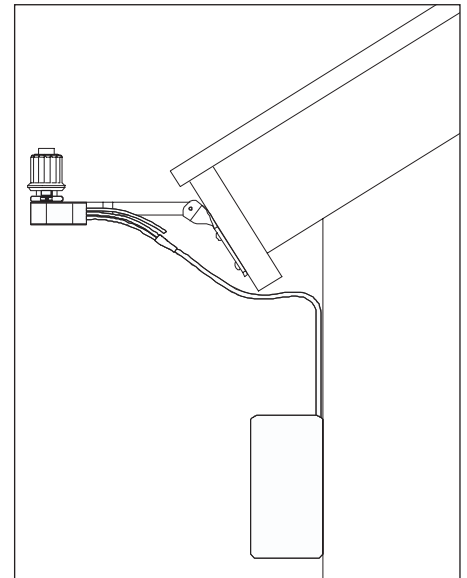
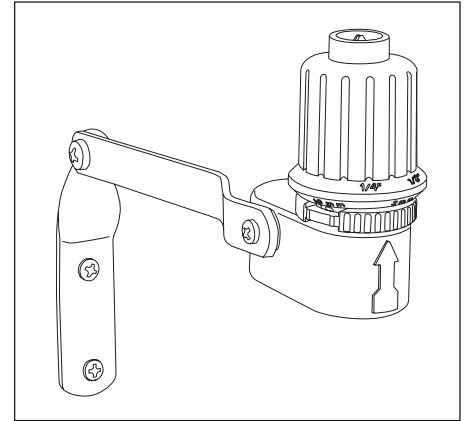
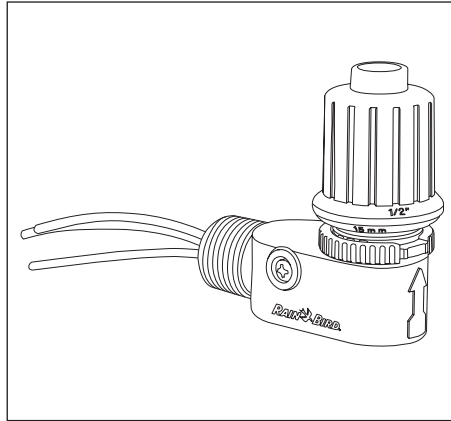

Rain Bird Corporation

Contractor Division

970 West Sierra Madre Avenue, Azusa, CA 91702

Phone: (626) 963-9311 Fax: (626) 812-3411

Rain Bird Corporation

Commercial Division

6991 East Southpoint Road, Tucson, AZ 85706

Phone: (520) 741-6100 Fax: (520) 741-6522

Rain Bird International, Inc.

145 North Grand Avenue, Glendora, CA 91741

Phone: (626) 963-9311 Fax: (626) 963-4287

Rain Bird Technical Service

(800) 247-3782 (U.S. only)

www.rainbird.com

Rain Bird. Conserving More Than Water.

® Registered trademark of Rain Bird Sprinkler Mfg. Corp.
© 2001 Rain Bird Sprinkler Mfg. Corp. 6/01

D39402C